



[www.spaandsauna.com](http://www.spaandsauna.com)

# Artesian Spas (Garden & South Seas models) Pre Delivery Information

## ELECTRICAL REQUIREMENTS

It is HIGHLY recommended that you make an appointment with your salesperson prior to delivery, so we can do an in-store orientation to go over the basics of the hot tub, and answer any questions you might have. The delivery crew is there to safely and professionally deliver your spa, but they are not electricians or contractors, nor water care experts. To ensure you will have an opportunity to use your spa soon after delivery, it is very important that you arrange the required electrical service to be installed after the delivery is scheduled. Your dealer may have electrical and building contractors they can refer you to, but the sale and delivery of the spa does not include any electrical or contracting work.

**IMPORTANT:** All electrical circuits must be installed by a qualified, licensed electrician.

## SELECTING THE VOLTAGE FOR YOUR SPA

- All Garden Series spas operate on 115 volts 15 amp (regular household outlets)
- The South Seas 519P model operates on 115 volts 20 amp 60 Hz.
- These models above can be converted to 220v / 50 amp
- All other South Seas spa models require 220v / 50 amp service

All electrical connections must be made in accordance with the wiring information contained in the electrical control box, or on the back of the field wiring access panel of the equipment module. All spas are configured at the factory and all wiring is done by the homeowner or their qualified electrician.

### 1. STANDARD, CORD-CONNECTED 115 VOLT 15 OR 20 AMP CONFIGURATION

For your safety, if you are having an electrician install an electric outlet for the spa it should be no closer than 5 feet (1.5 m) and no further than 10 feet (3 m) from the spa. [Reference National Electrical Code 680 - 6a(1) and 680 - 41a.]

One GFCI is used in the cord-connected 15 or 20 amp configuration. The GFCI module is located at or near the end of the power cord. To test the GFCI, simply press the TEST button. The GFCI should trip to the "off" position, disconnecting power to the spa. To reset the GFCI, press the RESET button. The GFCI

[info@spaandsauna.com](mailto:info@spaandsauna.com)



[www.spaandsauna.com](http://www.spaandsauna.com)

should reset, and power should be restored to the spa. If the GFCI does not function in this way, unplug the cord and contact your dealer.

NOTE: Consult your local code authority to determine if an electrical outlet with a cover is required for your installation. If it is, a suitable outlet cover can be purchased at most home supply stores.

### 115 VOLT 15 AMP ELECTRICAL REQUIREMENTS (Garden Series)

All Garden Series spas come configured to operate on a 15 amp circuit. The industry calls these “Plug & Play” because, in most situations, no special wiring is required. If you have a “regular outlet” on your patio, and it is not overloaded, a Garden Series spa will typically be able to operate on that circuit. **However, it is the responsibility of the homeowner to ensure that the outlet can handle the load of the Garden Series spa.**

### 115 VOLT 20 AMP ELECTRICAL REQUIREMENTS

The 519P spa model must be connected to a 115 volt, 20 amp grounded, dedicated circuit. The term “dedicated” means the electrical circuit is not being used for any other high-load electrical items (patio lights, appliances, garage circuits, etc.). If the spa is connected to a non-dedicated circuit, overloading will result in “nuisance tripping” of the internal fuses or of the breaker switch at the house electrical breaker panel.

The circuit must be properly wired; that is, it must have the following:

- Standard (cord-connected) 115 volt 20 amp (519P model) – A minimum 20 amp GFCI circuit breaker in the house panel, #12 AWG or larger wire (Depending on the length of the electrical run) and the correct polarity throughout the circuit. In addition to the dedicated 20 amp, 115 volt GFCI protected circuit, your spa requires a 20 amp single receptacle. This receptacle, which contains an outdoor-rated, weather-resistant receptacle cover plate, is required and should be installed by your electrician. This receptacle is not included with the spa and will need to be provided by your electrician.

### **NEVER CONNECT THE SPA TO AN EXTENSION CORD!**

Each Garden Series spa as well as the 519P spa comes equipped with approximately 15 feet (4.5 m) of usable power cord (this is the maximum length allowed by regulatory standards and the National Electric Code). The power cord is stored for shipping inside the spa. To remove the power cord, open the equipment compartment and locate the cord. Carefully pull the cord out of the equipment compartment to the desired length.

[info@spaandsauna.com](mailto:info@spaandsauna.com)



www.spaandsauna.com

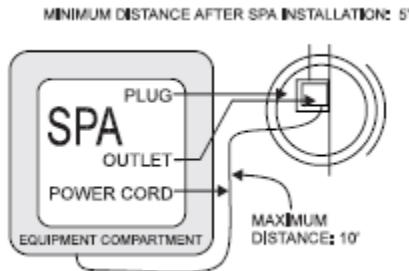

This is a picture of what your 115v spa will look like once you have the proper electrical outlet installed. The spa dealer is **not** licensed to do electrical and does **not** perform any electrical or contractor work needed or required for your hot tub.

## 220 / 230 VOLT WIRING (Including converting from 115/120 volt to 220/230)

(See Owner's Manual for Spa Wiring and Jumper / Dip Switch Configuration)

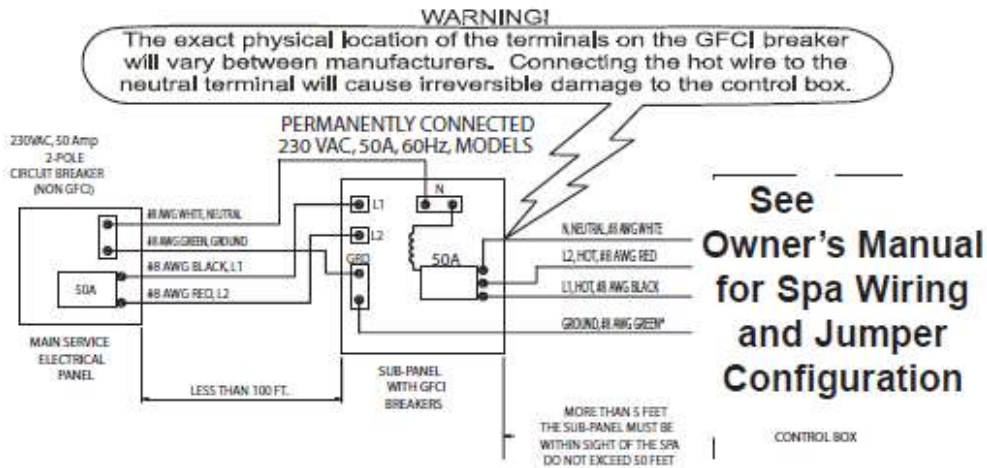

## 230 VOLT INSTALLATION (Required on all South Seas spas except the 519P – Optional wiring for the 519P and all Garden Series Spas)

Your South Seas 230 volt dedicated spas contains a control box designed to operate at 230V, 60Hz. Installation of a 50 amp dedicated circuit is required for All South Seas models (except the 519P) and optional for the 519P and all Garden Series spas. For 230 volt installation the control box of the spa must be hard wired directly to a subpanel protected by a Ground Fault Circuit Interrupter (GFCI). The subpanel containing GFCI breakers is not included with the spa and can be purchased at a home improvement or electrical supply store.

[info@spaandsauna.com](mailto:info@spaandsauna.com)



[www.spaandsauna.com](http://www.spaandsauna.com)

**IMPORTANT NOTE:** All electrical connections to the control box must be accomplished by a qualified electrician in accordance with the National Electrical Code and in accordance with any local electrical codes in effect at the time and place of installation.

All electrical connections must be made in accordance with the wiring information contained in this manual and on the back of the field wiring access panel of the control box. A licensed electrician should install a four-wire electrical service (two line voltages, one neutral, one ground) from the main electrical service panel to a subpanel with a 50 amp GFCI breaker. Your electrician should mount the subpanel in the vicinity of the spa but it should not be closer than five feet (1.5 m) from the spa water edge (NEC 680-38 to 41-A-3). **INSTALLATION NOTE:** After the spa has been installed, your electrician can connect the conduit from the subpanel to the spa's control box and then complete the wiring connections in the control box.

**WARNING: Removing or bypassing the GFCI breakers in the subpanel at any time will result in an unsafe spa and will void the warranty.**

## DELIVERY ACCESS

The dimensions of your spa are available on our website. A normal delivery is performed by the delivery crew setting the spa on its side, vertically on a cart or Spa Slider, and brought through a gate or opening that is at LEAST 1" to 2" wider than the spa height...

- Spas that are 36" tall require a minimum of 37" to 38" gate-width
- Spas that are 32" tall require a minimum of 33" to 34" gate-width

When measuring your width opening be sure to measure both the top of the width opening as well as the bottom of the width opening. Many times the posts holding the gate are different dimensions from top to bottom so be sure to measure top and bottom of the opening.

The Delivery Crew does not take gate and fence panels down to deliver the spa. If removal of gates, fences, or any other obstruction is required to deliver the spa, it is the responsibility of the homeowner to have this done prior to delivery.

This is the typical way we deliver spas:

[info@spaandsauna.com](mailto:info@spaandsauna.com)



www.spaandsauna.com

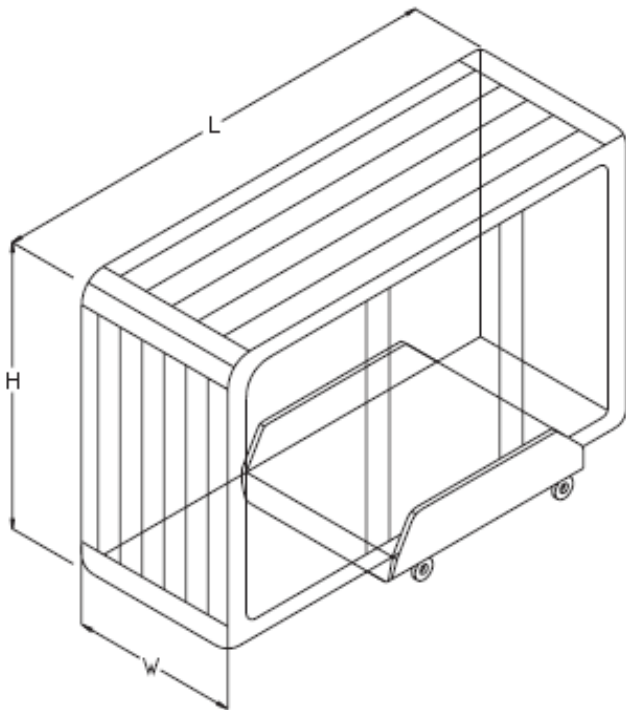

The “W” (width) shown in the picture to the left is the actual HEIGHT of your spa. We use different delivery implements so be sure to reference the instructions above for minimum width requirements.

The “H” in the diagram, and the “L” is the actual WIDTH and LENGTH of your spa... if you have a 7” x 7’ spa, both the “L” and “W” would be 7’... if you have a rectangular spa, the “L” and “W” are interchangeable... the delivery crew can tip the spa up either direction depending on your actual height clearance.

**NOTE:**

For WIDTH (“W”) clearance be sure to check for things like gas meters, water meters, or any other obstructions that would reduce the clearance going through the gate. Keep the length that the spa will be when tipped on its side in mind when measuring. For HEIGHT clearance (“H”) be sure to check eaves, trees, or any other obstructions that would block the spa being pushed through when on its side.

**NOTE:** It may be necessary to allow for additional overhead clearance if the spa will be pushed up or down an incline, or moved up or down a short flight of stairs.

Use the information on the next page to determine the requirements necessary to deliver your spa.

**The following is the responsibility of the homeowner and needs to be performed prior to delivery.** If The Delivery Crew arrives on the scheduled delivery date and obstructions or other hindrances prevent the Delivery Crew from safely and properly delivering the spa, the spa will be delivered into a garage or other safe location, If a second visit is required, a fee will be charged for a second delivery. The fee is determined by the location of the house and will be performed the next time the Delivery Crew is in the area.

All obstructions and delivery preparation is to be done PRIOR to the scheduled delivery date, and NOT at the time of the actual delivery.

[info@spaandsauna.com](mailto:info@spaandsauna.com)



[www.spaandsauna.com](http://www.spaandsauna.com)

- It may be necessary to remove a gate, part of a fence, or other movable obstructions in order to deliver the spa to its installation site.
- If there is an immovable obstruction such as a gas meter, AC unit, or other device that cannot be moved, and there is no other way to get the spa in, a crane will need to be scheduled at the time of delivery. All additional costs to accommodate the safe and proper delivery such as crane or fence removal is the responsibility of the customer – The Hot Tub Store does not have a crane but can provide referrals of licensed crane operators who can be hired to do the job.
- If there is a 90 degree turn, can we clear it? (The spa will not bend)
- Is the path clear?
- Move away branches, doghouses, firewood, etc.
- No more than 2 consecutive stairs without a landing.

NOTE – if there are stairs to go up you must inform the dealer prior to delivery. It is highly recommended that you take pictures and either email them to your salesperson, or bring them into the showroom for review. A video of the path from the driveway to the spa location is extremely helpful for determining delivery access.

We do NOT “Lift” spas over walls or fences. Spas are heavy, bulky, and our regular delivery crew is two or three people. We do not lift them up in any way... we place a spa on a sled system, or on a “Spa Slider”, tilt the spa on its side (for most deliveries), and lower them to the desired location. If delivery cannot be accomplished, we will either leave the spa in your garage, or some other safe location, or bring it back to the warehouse. In either case, an additional delivery fee will be assessed.

If the spa has to be craned don't be alarmed! Approximately 10% of the time a crane is the only way to install the spa by safely lifting it to its final destination. The crane has a truck-mounted boom which can fit right in your driveway. It is run by a licensed and insured operator. For a charge, the crane operator will lift your spa over walls, buildings, or any other obstruction, and place it as close to the installation site as possible. The Hot Tub Delivery Crew will supervise the crane delivery and complete the spa placement.

[info@spaandsauna.com](mailto:info@spaandsauna.com)



www.spaandsauna.com

## GROUND PREPARATION

The Artesian spa has been engineered to perform on all kinds of common yard surfaces. A concrete slab or properly supporting deck is best for long-term use, but other foundations are acceptable so long as a flat (preferably level) and secure base is prepared prior to delivery.

Three foundation base pictures, shown here, represent examples of base surfaces for spas. A Smartdeck plastic spa pad is also usable if installed on a flat hard surface.

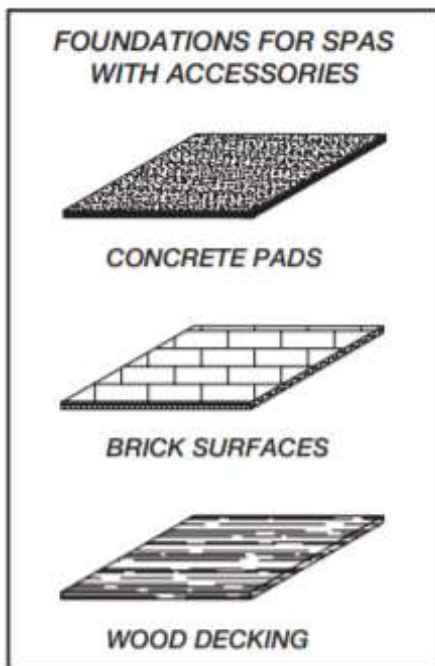

### INSTALLATION NOTES:

- A reinforced concrete pad at least four inches (10 cm) thick or structurally sound deck able to support the “dead weight” (approximately 9 pounds per gallon of water plus the dry weight of the spa) is recommended for your spa. If stepping stones or railroad ties are selected for the spa foundation, they should be placed under the entire spa area with a firm base underneath – road base, compacted gravel, etc.
- It is important to note that soft surfaces, even when stepping stones are used to distribute the weight of the spa as evenly as possible, will still have a tendency to settle unevenly, resulting in an unlevelled spa.
- If you are purchasing a recommended Smartdeck package for your spa, it requires a hard flat base material.

• As a homeowner, it is your responsibility to provide a suitable, flat foundation for your spa. Keep in mind that most spas are not able to be leveled, so the more level your flat surface, the better.

• If you are interested in having a concrete slab, paver, or wood deck installed, your dealer can often suggest a qualified, licensed contractor.

[info@spaandsauna.com](mailto:info@spaandsauna.com)



[www.spaandsauna.com](http://www.spaandsauna.com)

If you have any questions regarding pre-delivery information regarding your hot tub, please contact your salesperson or your Customer Engagement Representative and they will go over the details with you.

Thank you for your purchase.

Hot Spring Spas of Santa Cruz and San Jose

831-425-7727

[cerca@spaandsauna.com](mailto:cerca@spaandsauna.com) – for your Customer Engagement Representative

[deliveryca@spaandsauna.com](mailto:deliveryca@spaandsauna.com) – for Delivery Department

[info@spaandsauna.com](mailto:info@spaandsauna.com)